



City of Chicago  
Richard M. Daley, Mayor

Department of  
Procurement Services

Mary A. Dempsey  
Interim Chief Procurement Officer

City Hall, Room 403  
121 North LaSalle Street  
Chicago, Illinois 60602  
(312) 744-4900  
(312) 744-2949 (TTY)  
<http://www.cityofchicago.org>

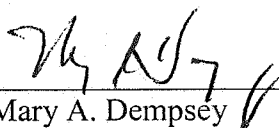
Date: June 30, 2005  
To: Cheri Heramb, Acting Commissioner  
Department of Transportation  
Attn: Gilberto Quinones  
From:   
Mary A. Dempsey  
Interim Chief Procurement Officer  
Re: Emergency Purchase Order Authorization

Pursuant to Section 2-92-644 of the Municipal Purchasing Act, I am authorizing you to make an Emergency purchase from Silica Glass Co. Based upon information received from members of your staff, I have determined that this procurement is necessary to meet bona fide operating emergencies.

You are hereby authorized to purchase '200 pieces of Annealed Glass Panels (30" x 30" x 3/16") with seamed edges and 1 1/2" radius rounded corners' in the amount of \$10,000.00 as requested in your letter of June 21, 2005. Any amount in excess of the \$10,000.00 approved here will be subject to additional authorization and will be limited so as not to exceed the \$250,000 limit established by statute.

cc: Lourdes Nur  
Claude Humphrey





June 21, 2005

City of Chicago  
Richard M. Daley, Mayor

Department of Transportation

30 North LaSalle Street  
Suite 1100  
Chicago, Illinois 60602-2570  
(312) 744-3600  
(312) 744-7215 (TTY)  
www.cityofchicago.org/transportation

To: Mary A. Dempsey  
Interim Chief Procurement Officer  
Department of Procurement Services  
121 North LaSalle Street – Room 403  
Chicago, Illinois 60602

RE: REPLACEMENT GLASS PANELS FOR LIFE RING CABINETS

Dear Mrs. Dempsey:

The Department of Transportation, Division of In-House Construction (Bridges) is requesting an emergency purchase of annealed glass panels-size (30" x 30" x 3/16") with seamed edges and 1 1/2" radius rounded corners. The glass replacement panels are required to protect the life rings stored inside cabinets on the waterways from theft, improper removal and weather damage. The life rings are needed for emergencies that may occur on the Chicago and Calumet Rivers as well as the lagoons located throughout Chicago. The glass replacement panels are to be crated with protective packaging and delivered in lots of 25.

We ask that 200 pieces of annealed glass panels be purchased by way of an emergency purchase order not to exceed \$10,000. This amount should satisfy the Department's needs for approximately 6 months until a new contract is awarded. A price quote from Silica Glass Co., whose product meets CDOT specifications, has been obtained. See attached.

The Department of Transportation is requesting your immediate attention for an emergency contract.

If additional information is required, please contact Lou Langone at 312-744-5717. Your help in expediting our request at your earliest convenience will be greatly appreciated.

Sincerely

Cheri Heramb  
Acting Commissioner  
Department of Transportation

Originated by:

  
William Cheaks  
Deputy Commissioner  
Division of In House Construction

Reviewed by: Lou Langone

cc: C. Heramb T. Powers W. Cheaks G. Quiñones  
J. Goliber L. Langone M. Forniciari J. Bracewell  
File

(SEE ATTACHMENTS)



## **SPECIFICATION NO.**

### **GLASS PANEL FOR LIFE PRESERVER BOXES**

#### **1.0 INTENT**

1.01 It is the intent of these specifications to describe a glass panel for the life preserver boxes located on various bridges for use by the Department of Transportation.

#### **2.0 OVERALL DESIGN-see attached Diagrams**

2.01 Length 30"

2.02 Height 30"

2.03 Width 3/16"

2.04 Seamed Edges

2.05 4 Rounded Corners w/ 1 1/2" radius

#### **3.0 PACKAGING**

3.01 Crated and Protected in Bundles of 25

Scale: 1/8 : 1

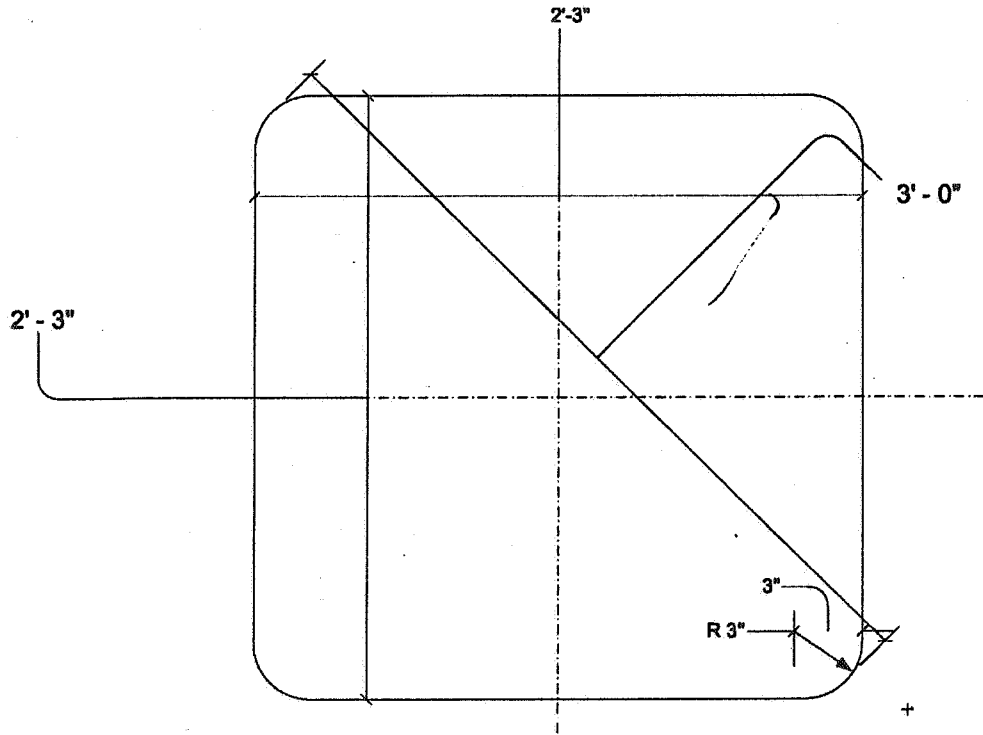

**CITY OF CHICAGO  
DEPARTMENT OF TRANSPORTATION  
DIVISION OF ADMINISTRATION**

**Description:**

**THE FOLLOWING COMPANIES ARE SUGGESTED VENDORS:**

<b>COMPANY</b>	<b>CONTACT NAME</b>	<b>PHONE NUMBER</b>	<b>FAX NUMBER</b>
Silica Glass	Mustafa	773.463.4451	773.463.8030

# CPAC PROJECT CHECKLIST

For CPAC Team Use Only

Date Received \_\_\_\_\_

Date Returned \_\_\_\_\_

Date Accepted \_\_\_\_\_

**IMPORTANT:** PLEASE READ AND FOLLOW THE INSTRUCTIONS FOR COMPLETING THE PROJECT CHECKLIST AND CONTACT THE APPROPRIATE TEAM LEADER IF YOU HAVE ANY FURTHER QUESTIONS. ALL INFORMATION SHOULD BE COMPLETED INCLUDING THE SUPPLEMENTAL CHECKLIST REQUIRED BY THE SPECIFIC CPAC TEAM. ATTACH ALL REQUIRED MATERIALS AND SUBMIT FOR HANDLING TO THE DEPARTMENT OF PROCUREMENT SERVICES, ROOM 403, CITY HALL, 121 N. LASALLE STREET, CHICAGO, ILLINOIS 60602.

RX# 21862

**PROJECT**  
 Date: 6/30/05  
 ID No (Spec, RX, Project): 37775  
 Department: CDOT  
 Bureau: In House Construction  
 Contract No (if known): \_\_\_\_\_  
 Project Title/Description: Emergency for Replacement Glass Panels & over life ring cabinets

Contact Person: Jim BRACWELL  
 Tel: 4-3106 Fax: 4-4399 E-mail: \_\_\_\_\_  
 Project Manager: Lou LANGONE  
 Tel: 656-4399 Fax: 4-4399 E-mail: \_\_\_\_\_  
 Estimated Value \$ 10,000

**SCOPE STATEMENT**

\_\_\_\_\_ attached is a detailed scope of services and/or specification

N/A

**IMPORTANT:** THIS IS A CRITICAL PORTION OF YOUR SUBMITTAL. IN ORDER FOR A TEAM TO ACCEPT YOUR SUBMITTAL YOU MUST COMPLETE ALL TEAM SPECIFIC SCOPE REQUIREMENTS AS SET FORTH IN THE SUPPLEMENTAL CHECKLIST FOR THAT TEAM.

The following is a general description of what would be included in a Scope of Services or Specification:  
 A clear description of all anticipated services and products, including: time frame for completion, special qualifications of prospective vendors, special requirements or needs of the project, locations, anticipated participating user departments, citation of any applicable City ordinance or state/federal regulation or statute.

**TYPE OF PROCUREMENT REQUESTED (check all that apply)**

Competitive Bid     RFQ/RFP/RFS/RFI     Sole Source\*\*     Term Agreement     One Shot  
 Mod/Amendment     Time Extension     Additional Funding     Small Order     S/O Emergency

**FORMS**

F-25\* (add line item)     F-10\* (special approvals)     SSRB\*\* (sole source approval)  
 F-26\* (new term agreement)     RX (one-shot requisition)     OBM Authorization  
 F-27\* (time extension)     APRF (all purpose request form)  
 F-29\* (change vendor limit)

\*\* Sole source requests must include vendor quotes/proposal and MBE/WBE compliance requirements

**FUNDING**

City:  Corporate     Bond     Enterprise     Grant\*     Other \_\_\_\_\_  
 State:  IDOT/Transit     IDOT/Highway     Grant\*     Other \_\_\_\_\_  
 Federal:  FHWA     FTA     FAA     Grant\*     Other \_\_\_\_\_  
 Funding Strip(s): 05 0310 08421SS 6618 22 0340

\* Attach copy of any applicable grant agreement terms and conditions

**TIME FRAME**

Date Needed: ASAP

Requested Contract Term (y/m/d): N/A

**PRE BID/SUBMITTAL REQUIREMENTS**

Requesting Pre Bid/Submittal Conference?  Yes  No    Requesting Conference be Mandatory?  Yes  No  
 Requesting Site Visit?  Yes  No    Requesting Site Visit be Mandatory?  Yes  No

N/A